

BK-G6 and BK-G6T

Compact residential diaphragm gas meters, cyclic volume 2 dm³



Applications

Media: Natural gas, town gas, propane, butane air. *
Industry: Gas supply
Tasks: Gas measurement at operating conditions. **

Brief information

The residential diaphragm gas meter BK-G6 meet the highest demands with respect to accuracy of measurement and safety. It incorporates both innovative features and gas measurement know-how of many decades. The BK-G6 is supplied in folded form as co-axial and two-pipe version.

The stroke of the diaphragms is pneumatically stopped and therefore ensures both low bearing loads and a quiet operation.
The synthetic diaphragm is dimensionally stable and stadium shaped.

High-grade materials and components as well as the patented curve K-system ensure a high quality standard.

The K-System perfectly coordinates the movement of the valves with the actual gas flow to the measuring chambers. This ensures excellent linearity even with utilizing small valves.

Due to the optimised slides, Q_{\min} of BK-G6 is stable and the gas meter is not susceptible to contamination (RPF 0.9 to BS4161). The measuring unit is adjusted by a patented needle-and-scale system.

Although the design of the BK-G6 is very robust, the gas meters are still measuring instruments and as such should be handled with care.

Operating principle: Four measuring chambers are separated by synthetic diaphragms. The chambers are filled and emptied periodically, and the movement of the diaphragms is transferred via a gear to the crankshaft. This shaft moves the valves, which control the gas flow. The rotations of the gear are transferred via a magnetic coupling to the index.

The temperature compensation facility of the BK-G6T ensures via a bimetallic element that the stroke of the diaphragms is adapted to the current gas temperature.

Main features

- MID conformity approved by PTB
- Approved to EN 1359 by German DVGW
- EU approval by German PTB
- Flow rates from 0.06 m³/h to 10 m³/h
- Cyclic volume 2 liters
- Maximum working pressure 0.5 bar
- Firesafe (HTB) up to 0.1 bar acc. to EN 1359
- High accuracy and long-term stability
- Powder coated pale grey to RAL 7035
- Standard pulse magnet; retrofitable LF pulser (I=0.01 m³/pulse)
- Not susceptible to contamination (RPF = 0.9)
- Temperature ranges on request
- Temperature compensation available
- Intelligent index technology, Chekker system, Absolute-ENCODER and radio applications

* Other media: Inert gases to EN 437

** BK-G6T: Measurement of temperature-compensated gas volume

BK-G6 and BK-G6T : Compact residential diaphragm gas meters, cyclic volume 2 dm³

Dimensions

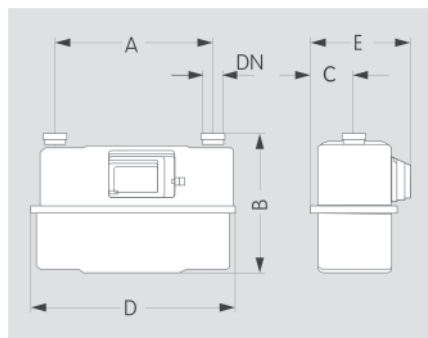

Dimensions and weights

Dimensions [mm]					Connection size	Thread	Weight
A	B	C	D	E	DN *		(kg)
152.4	262	71	226	163	-	1" [BS 746]	3.0
152.4	252	71	226	163	25	1 1/4"	3.0
250	250	71	327	163	20	1"	3.5
250	241	71	327	163	25	1 1/4"	3.5

* To DIN 3376

Additional connection dimensions on request

Error curve

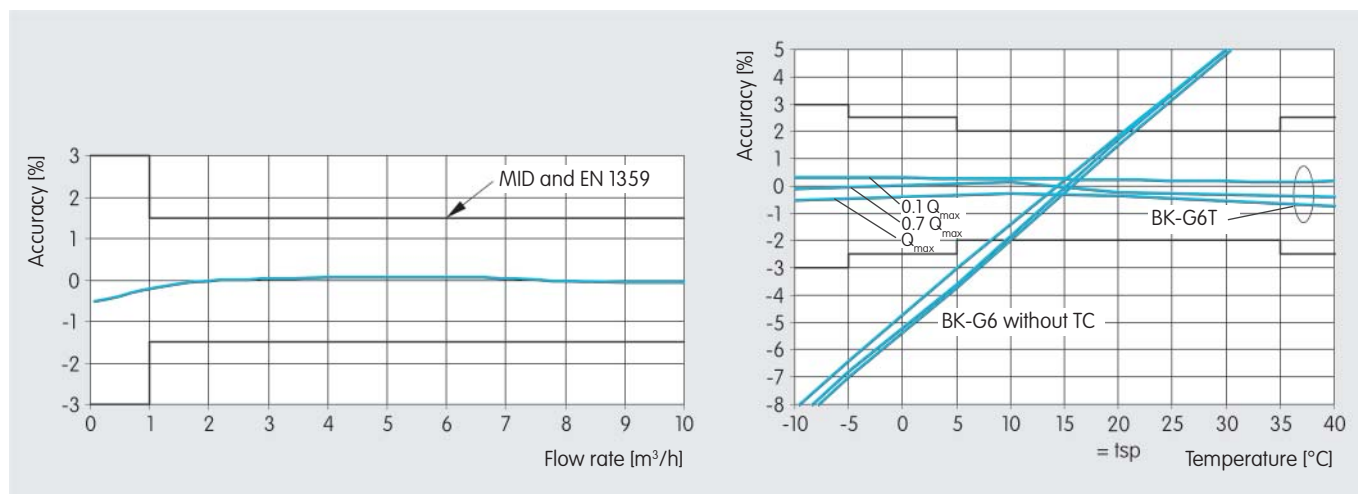

With calibration error limits at test room temperature

For BK-G6T within the compensation range with error limits to EN 1359:1998/A1:2006, Annex B

Pressure drop curve

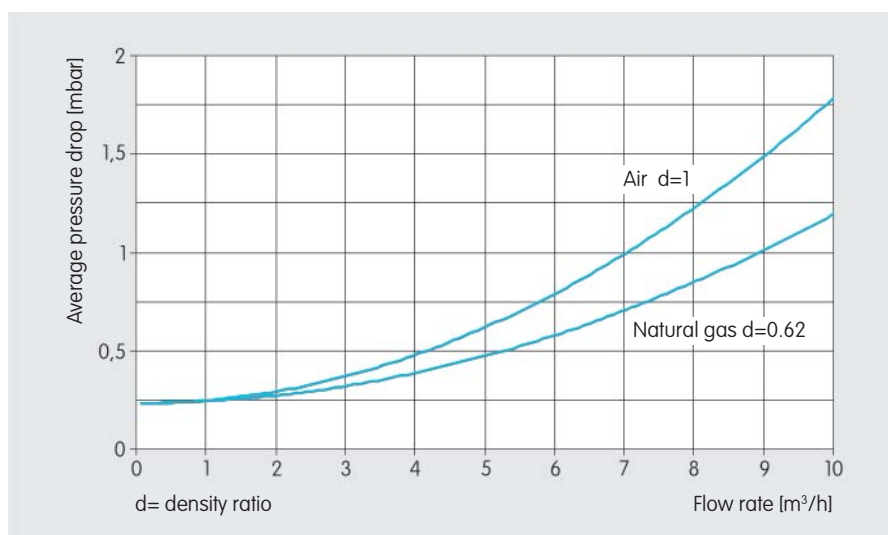

Your contacts

Germany
Elster GmbH
Steinern Str. 19 - 21
55252 Mainz-Kastel
T +49 6134 605 0
F +49 6134 605 223
www.elster-instromet.com
info@elster-instromet.com

Belgium
Elster-Instromet N.V.
Rijkmakerlaan 9
2910 Essen
T +32 3 670 0700
F +32 3 667 6940
www.elster-instromet.com
info@elster-instromet.com

Singapore
Elster-Instromet
Singapore Representative Office
80 Marine Parade Road
09-04 Parkway Parade
Singapore 449269
T +65 6247 7728
F +65 6247 7729

BK G6 V2 EN02

A19.02.2008